

GEN. TOLERANCES	0.5 - 6	±0.1	6 - 30	±0.2	30 - 120	±0.3	120 - 315	±0.5	315 - 1000	±0.8	1000 - 2000	±1.2	2000 - 4000	±2	4000 - 8000	±3
GEN. MACHINING	▽	0.4	▽	1.6	3.2	▽	6.3	▽	12.6	▽	25 ROUGH	▽		▽		

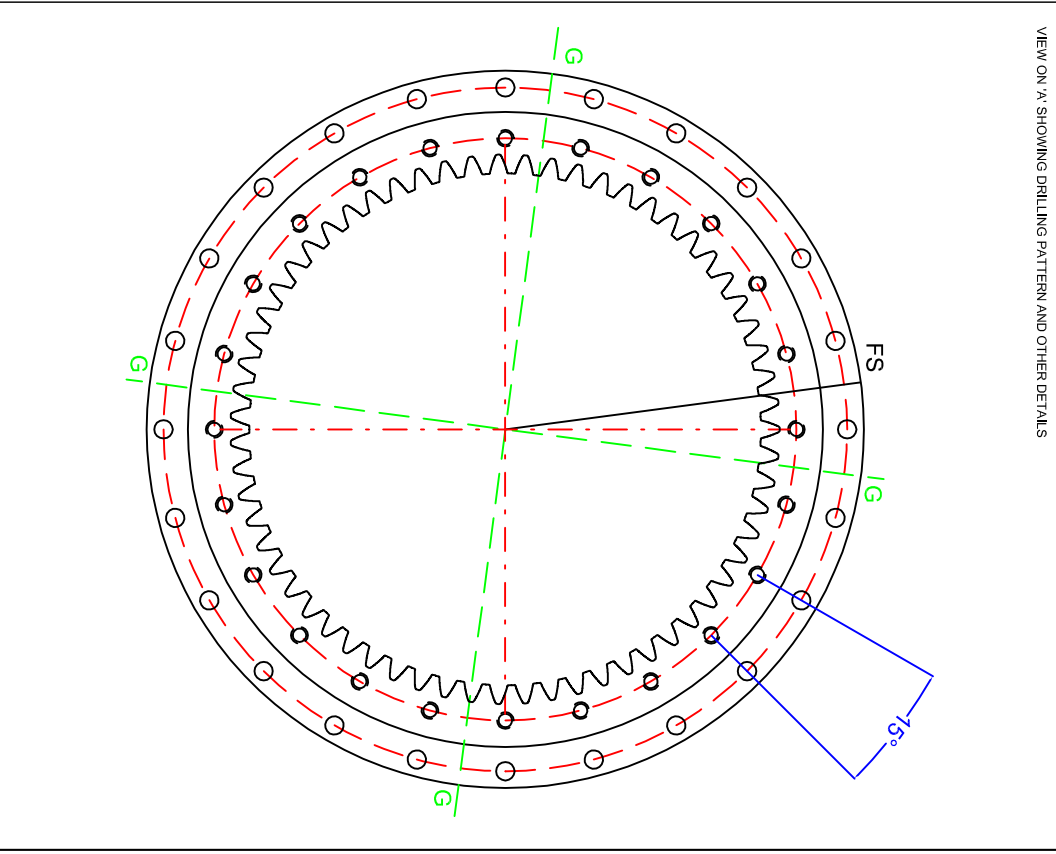
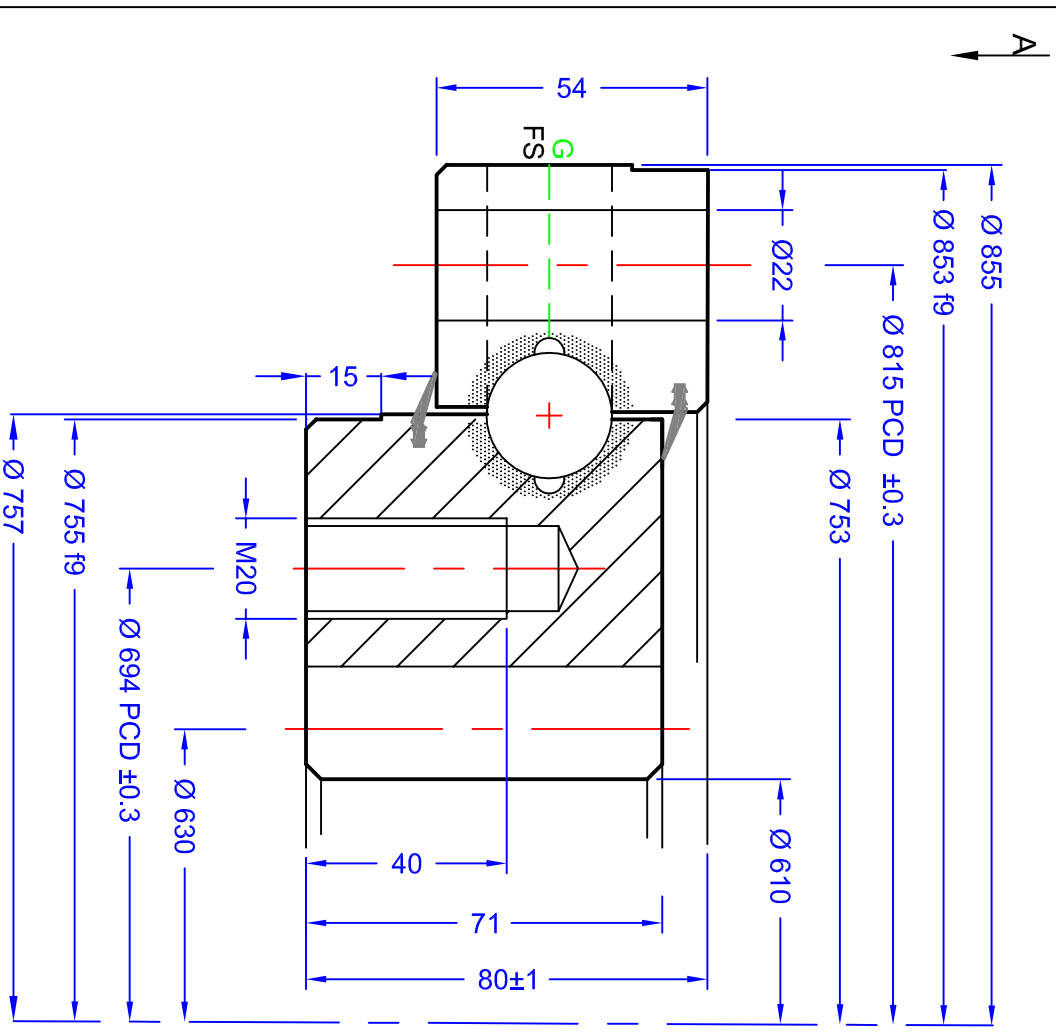

VIEW ON 'A' SHOWING DRILLING PATTERN AND OTHER DETAILS

GEAR DATA	SPUR	WORM	HELICAL
HARDED GEAR	NO		
NUMBER OF TEETH (Z)	63	MODULE (M)	10
PRESSURE ANGLE (α)	20°	DP	
ADDENDUM COEFFICIENT (X)	0		
PROFILE CORRECTION (Y)	0	CALCULATED GEAR STRENGTH	
TRUNCATION (R)	0	Fz (Normal)	KN
PITCH CIRCLE DIAMETER	630 mm	Fz (Face)	KN
MEASUREMENT ON K TEETH	mm	Pin Diameter	mm
RUNOUT NOT HARDENED/HARDENED		LOADING PLUG	'FS'
		SEAL SIZE	TBA

Designed in accordance with designated QCB SLEWING RING STANDARDS

Non tolerated dimensions to ISO 2768-1 m

All burrs and sharp edges to be removed. Standard corner chamfer 1mm x 45°

Internal radial and axial clearance figures to QCB standard 2014 or revisions thereof

The HARNESS GAP is to be indicated by stamped letter 'R' or a PAINT mark on the exterior surface

The high point of gear eccentricity to be indicated by GREEN or BLUE paint on 3 teeth

BOLT DATA	INNER	OUTER	GREASE HOLES	LOADING PLUG	SEAL SIZE
24 =	24 =	4 X M8	'G'	'FS'	TBA

AXIAL PLAY	RADIAL PLAY	TURNING TORQUE	WEIGHT
0.12-0.28 mm	0.12-0.28 mm	420Nm/0.4kT	119 kg (est)

REV	DATE	MODIFICATION	REVISED BY
1			

QCB
Bearings

SLEWING
RINGS &
DRIVES

Orelton Lane, Wellington, Telford, TF1 2BG, UK

P: 01962 222300 F: 01962 242938
www.nbcbgroup.co.uk

QCB® is a registered trademark of NBC Group Ltd

Imported by NBC Group Ltd

DATE: 02/02/2016

CHECKED: LJM

SIG 855 25 01 AA LM

QCB RS 11/2016