

GEN. TOLERANCES	0.5 - 6	±0.1	6 - 30	±0.2	30 - 120	±0.3	120 - 315	±0.5	315 - 1000	±0.8	1000 - 2000	±1.2	2000 - 4000	±2	4000 - 8000	±3
GEN. MACHINING	▽	0.4	▽	1.6	▽	3.2	6.3	▽	12.6	▽	25 ROUGH	▽	▽	▽	▽	▽

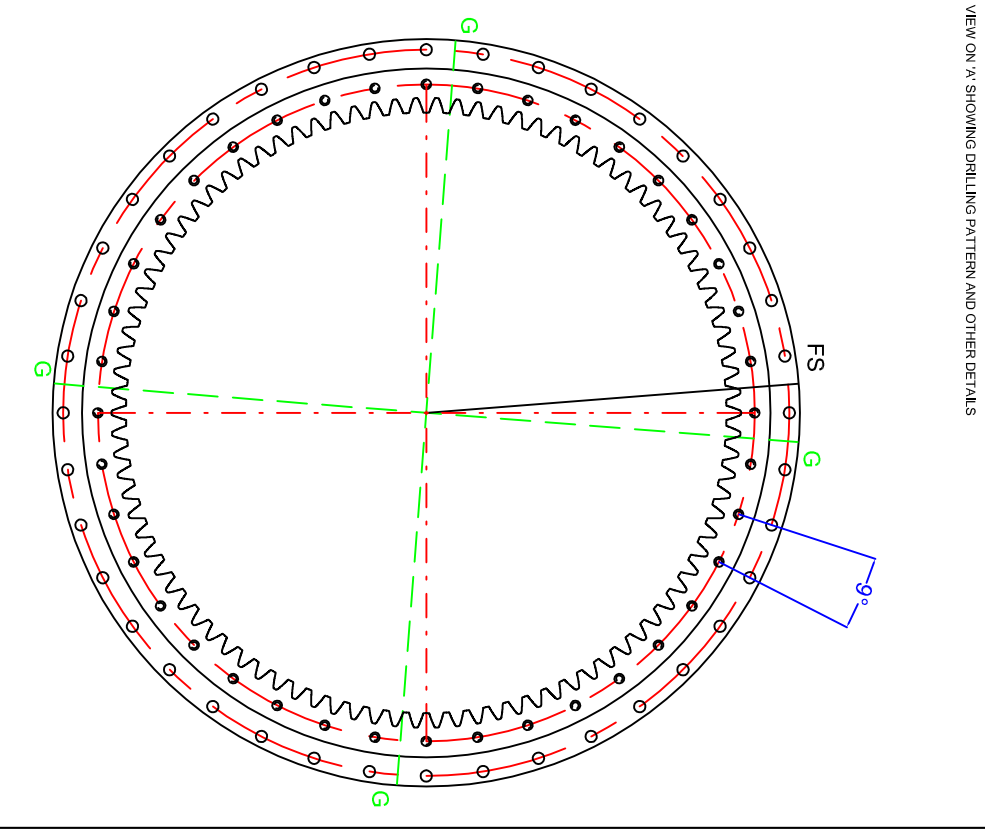
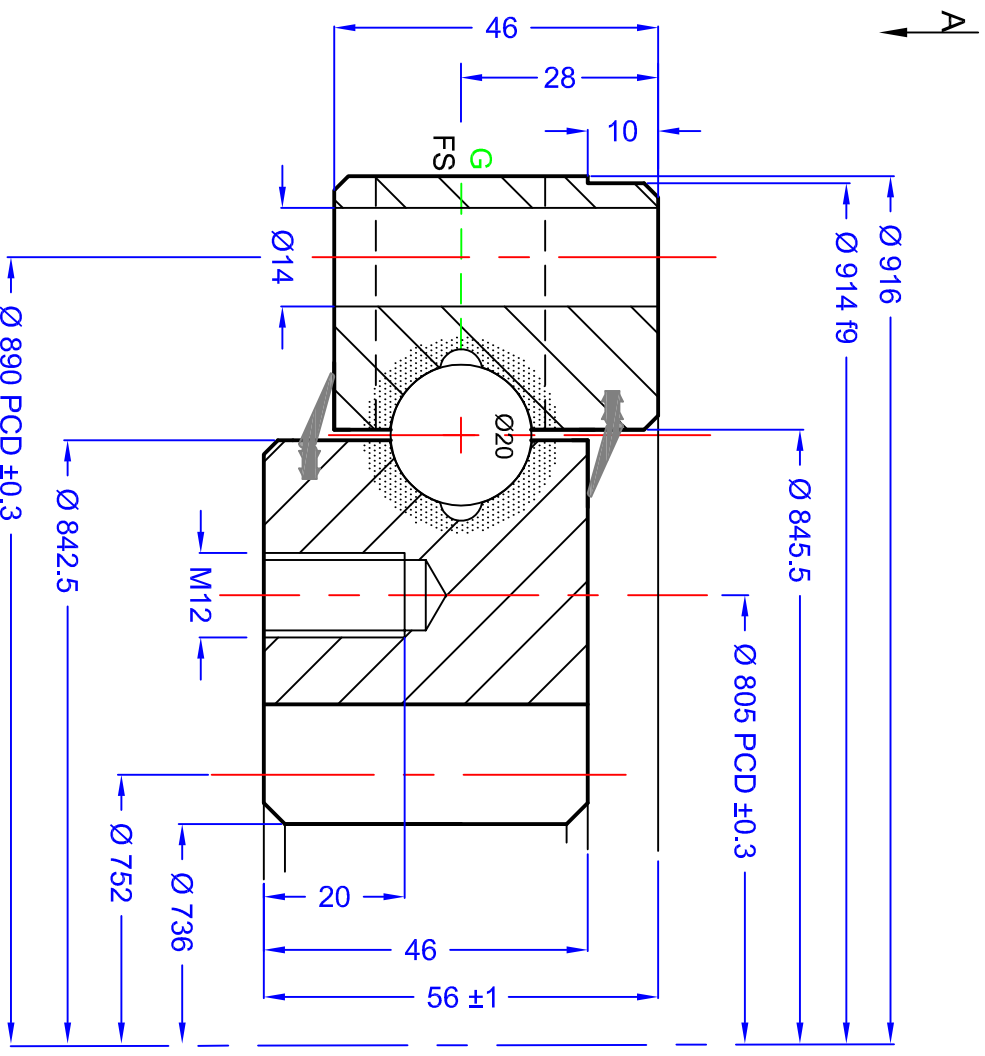

VIEW ON 'A' SHOWING DRILLING PATTERN AND OTHER DETAILS

GEAR DATA	SPUR	WORM	HELICAL
-----------	------	------	---------

HARDED GEAR	NO	MODULE (m)	8
NUMBER OF TEETH (z)	94	DP	
PRESSURE ANGLE (α)	20°	CALCULATED GEAR STRENGTH	
ADDENDUM COEFFICIENT (x)	0	INNER	40 =
PROFILE CORRECTION (y)	0	OUTER	40 =

TRUNCATION (mm)	0	Fz (Normal)	KN
PITCH CIRCLE DIAMETER	752 mm	Fz (Allow)	KN
MEASUREMENT ON K TEETH	mm	Pin Diameter	mm
RUNOUT NOT HARDED/HARDED		LOADING PLUG	'FS'
		SOFT ZONE	'R'
		SEAL SIZE	TBA

DESIGNED IN ACCORDANCE WITH DESIGNATED QCB SLEWING RING STANDARDS
 Non toleranced dimensions to ISO 2768-1 m
 All burrs and sharp edges to be removed. Standard corner chamfer 1mm x 45°
 Internal radial and axial clearance figures to QCB standard 2014 or revisions thereof.
 The HARDNESS GAP is to be indicated by stamped letter R or a PAINT mark on the exterior surface.
 The high point of gear eccentricity to be indicated by GREEN or BLUE paint on 3 teeth

DESIGNED IN ACCORDANCE WITH DESIGNATED QCB SLEWING RING STANDARDS

Non toleranced dimensions to ISO 2768-1 m
 All burrs and sharp edges to be removed. Standard corner chamfer 1mm x 45°
 Internal radial and axial clearance figures to QCB standard 2014 or revisions thereof.
 The HARDNESS GAP is to be indicated by stamped letter R or a PAINT mark on the exterior surface.
 The high point of gear eccentricity to be indicated by GREEN or BLUE paint on 3 teeth

BOLT DATA	INNER	40 =	MOUNTING HOLES	M12	TURNING TORQUE	Nm
	OUTER	40 =	MOUNTING HOLES	Ø 14	MATERIAL	42CrMo4 Q&T
	GREASE HOLES	G'	4 X M8	WEIGHT	69 kg (est)	
	LOADING PLUG	'FS'	SOFT ZONE	'R'	REFINISH (standard)	
	SEAL SIZE	TBA				

DESIGNED IN ACCORDANCE WITH DESIGNATED QCB SLEWING RING STANDARDS

REV	DATE	MODIFICATION	REVISED BY
1			

QCB Bearings SLEWING RINGS & DRIVES

Imported by NBC Group Ltd
 Orleton Lane, Wellington, Telford, TF1 2BG, UK
 P: 01962 222300 F: 01962 242938
 www.nbcgroup.co.uk

QCB® is a registered trademark of NBC Group Ltd

SIG 916 20 01 AA LM

QCB RS 11/2016

DATE: 05/01/2016
 CHECKED: LM